



INDIAN SCHOOL AL WADI AL KABIR

Assessment - 1

Class: XII

Sub: MATHEMATICS (041)

Max Marks: 80

Date: 26.09.2023

Time: 3 hr

General Instructions:

1. This question paper is divided in to 6 sections- A, B, C, D and E
2. Section A comprises of 20 MCQ type questions of 1 mark each.
3. Section B comprises of 5 Very Short Answer Type Questions of 2 marks each.
4. Section C comprises of 6 Short Answer Type Questions of 3 marks each.
5. Section D comprises of 4 Long Answer Type Questions of 5 marks each.
6. Section E comprises of 3 source based / case based / passage-based questions (4 marks each) with sub parts.
7. Internal choice has been provided for certain questions

SECTION – A

(Each MCQ Carries 1 Mark)

1. If $f'(x) = 4x^3 + \frac{3}{x^4}$, such that $f(2) = 0$, then $f(x)$ is
a) $x^4 + \frac{3}{x^3} - \frac{129}{8}$ b) $x^3 + \frac{3}{x^4} + \frac{129}{8}$ c) $x^4 + \frac{3}{x^3} + \frac{129}{8}$ d) $x^3 + \frac{3}{x^4} - \frac{129}{8}$
2. The value of 'k' for which the function $f(x) = \begin{cases} k \cos x & , \text{if } x \neq \frac{\pi}{2} \\ 3, & \text{if } x = \frac{\pi}{2} \end{cases}$ is continuous at $x = \frac{\pi}{2}$ is
a) 0 b) 6 c) 1 d) 2
3. Find k, if $A = \begin{bmatrix} -2 & 3 \\ 4 & k \end{bmatrix}$ is a singular matrix
a) -6 b) $-\frac{3}{8}$ c) 6 d) $\frac{8}{3}$
4. The value of $\int_2^3 \frac{x}{x^2 + 1} dx$ is
a) $\log 4$ b) $\log \frac{3}{2}$ c) $\frac{1}{2} \log 2$ d) $\log \frac{9}{4}$
5. The value of $\sin^{-1} \left[\sin \left(\frac{3\pi}{5} \right) \right]$ is
a) $\frac{13\pi}{7}$ b) $-\frac{13\pi}{7}$ c) $\frac{2\pi}{5}$ d) $-\frac{\pi}{7}$

- 6 The total revenue in Rupees received from the sale of x units of a product is given by $R(x) = 5 + 36x + 3x^2$. The marginal revenue when $x = 15$ is.
- a) ₹ 42 b) ₹ 72 c) ₹ 114 d) ₹ 126
- 7 $\int \frac{x}{(x-1)(x-2)} dx$ equals
- a) $2\log |x-1| - \log |x-2| + C$ c) $-\log |x-1| - 2\log |x-2| + C$
b) $\log |x-1| - \log |x-2| + C$ d) $\log |x-2| - \log |x-1| + C$
- 8 The number of all possible matrices of order 3×3 with each entry 0 or 1 is
- a) 27 b) 1 c) 81 d) 512
- 9 Let $\sin^{-1}(1-x) + 2\sin^{-1}x = \frac{\pi}{2}$. Then the value of 'x' is
- a) $0, \frac{1}{2}$ b) $1, \frac{1}{4}$ c) $\frac{1}{2}$ d) 0
- 10 Let A be a non-singular matrix of order 3×3 . Then $|adj A|$ is equal to
- a) $|A|$ b) $|A|^2$ c) $|A|^3$ d) $3|A|$
- 11 If $y = a \cos mx + b \sin mx$, then $\frac{d^2y}{dx^2}$ is
- a) m^2y b) $-m^2y$ c) my d) $-my$
- 12 Value of $\int \frac{\cos \sqrt{x}}{\sqrt{x}} dx$ is
- a) $-2\sin \sqrt{x} + c$ b) $\sin \sqrt{x} + c$ c) $2 \cos \sqrt{x} + c$ d) $2 \sin \sqrt{x} + c$
- 13 For the function $y = \frac{(x-5)}{(x-4)(x-3)}$, the value of $\left(\frac{dy}{dx}\right)_{at x=2}$ is
- a) -20 b) $\frac{7}{4}$ c) $\frac{-7}{4}$ d) 20
- 14 The rate of change of area of a circle with respect to its radius 'r' at $r = 6$ cm is
- a) 10π cm b) 12π cm c) 8π cm d) 11π cm
- 15 Find x if $\begin{vmatrix} 3 & -6 \\ 4 & 0 \end{vmatrix} = \begin{vmatrix} 3 & x^2 \\ x & -1 \end{vmatrix}$
- a) 4 b) $\sqrt{-6}$ c) -3 d) None of these

- 16 What are the turning points of the function $f(x) = x(x - 1)^2$, $0 \leq x \leq 2$?
- a) 2, 8 b) $\frac{1}{2}, \frac{1}{4}$ c) $1, \frac{1}{3}$ d) $\frac{1}{3}, 0$
- 17 If $f(x) = \log x$, then $f'(x) + f'\left(\frac{1}{x}\right)$ is
- a) $\frac{x^2-1}{x}$ b) $\frac{1-x^2}{x}$ c) $\frac{x^2+1}{x}$ d) $\frac{1+x}{x}$
- 18 If $y = \log \sqrt{\tan x}$, then the value of $\frac{dy}{dx}$ at $x = \frac{\pi}{4}$
- a) ∞ b) 1 c) $\frac{1}{2}$ d) 0

Directions: In the following 2 questions, A statement of Assertion (A) is followed by a statement of Reason (R). Mark the correct choice as.

- (A) Both A and R are true and R is the correct explanation of A
 (B) Both A and R are true but R is NOT the correct explanation of A
 (C) A is true but R is false
 (D) A is false and R is True

- 19 **Assertion (A):** If A is a square matrix such that $A^2 = A$, then $(I + A)^2 - 3A = I$
Reason (R): $AI = IA = A$
- a) b) c) d)
- 20 **Assertion (A):** The relation $f: \{1, 2, 3, 4\} \rightarrow \{x, y, z, p\}$ defined by $f = \{(1, x), (2, y), (3, z)\}$ is a bijective function.
Reason (R): The relation $f: \{1, 2, 3\} \rightarrow \{x, y, z, p\}$ such that $f = \{(1, x), (2, y), (3, z)\}$ is one-one
- a) b) c) d)

SECTION – B

(Each Question Carries 2 Marks)

21 If $A = \begin{bmatrix} 1 & 2 & 2 \\ 2 & 1 & x \\ -2 & 2 & -1 \end{bmatrix}$ is a matrix satisfying $AA' = 9I$, find x

22 Evaluate $\int_0^1 \frac{x e^x}{(1+x)^2} dx$

- OR -

Evaluate $\int_1^{\frac{\pi}{2}} \frac{\sqrt{\sin x}}{\sqrt{\sin x} + \sqrt{\cos x}} dx$

23 Find the value of $\cos^{-1} [\cos (\pi)] + \sin^{-1} (\sin \frac{3\pi}{4}) + \tan^{-1} (1)$

- OR -

Find the domain of $\sin^{-1} (x^2 - 4)$

24 A function f where $f: N \rightarrow Z$ such that

$$f(x) = \begin{cases} \frac{n+1}{2}, & \text{if } n \text{ is odd} \\ -\frac{n}{2}, & \text{if } n \text{ is even} \end{cases}$$

Is the function injective? Justify your answer.

25 Find the value of 'a' and 'b' such that the function defined is a continuous function

$$f(x) = \begin{cases} 1, & \text{if } x \leq 3 \\ ax + b, & \text{if } 3 < x < 5 \\ 7, & \text{if } x \geq 5 \end{cases}$$

SECTION – C

(Each Question Carries 3 Marks)

26 Find $\frac{dy}{dx}$ if $x = \frac{1+\log t}{t^2}$ and $y = \frac{3+2 \log t}{t^2}$, $t > 0$

27 Integrate the function $\int \frac{2x}{(x^2+1)(x^2+4)} dx$

- OR -

Evaluate $\int_1^4 \{ |x - 1| + |x - 2| + |x - 3| \} dx$

28 The volume of a cube is increasing at a rate of 8 cubic centimetres per second. How fast is the surface area increasing when the length of an edge is 12 centimetres?

- OR -

A balloon, which always remains spherical, has a variable diameter $\frac{3}{2}(2x + 1)$. Find the rate of change of its volume with respect to x .

29 Let $f: R_+ \rightarrow [-5, \infty)$ be a function defined as $f(x) = 9x^2 + 6x - 5$. Show that the function $f(x)$ is one-one and onto.

- OR -

Check whether a function $f: R \rightarrow \left[-\frac{1}{2}, \frac{1}{2}\right]$ defined as $f(x) = \frac{x}{(1+x)^2}$ is one-one or onto or not

30 Express the matrix $A = \begin{bmatrix} 1 & 3 & -5 \\ -6 & 8 & 3 \\ -4 & 6 & 5 \end{bmatrix}$ as the sum of a symmetric and skew symmetric matrix.

31 If $y = \frac{\log x}{x}$, show that $\frac{d^2y}{dx^2} = \frac{2 \log x - 3}{x^2}$

SECTION – D

(Each Question Carries 5 Marks)

- 32 Define the relation R in the set $N \times N$ as follows:
For $(a, b), (c, d) \in N \times N$, $(a, b) R (c, d)$ iff $ad = bc$.
Prove that R is an equivalence relation in $N \times N$.

- OR -

Show that the function $f: \mathbb{R} \rightarrow \{x \in \mathbb{R} : -1 < x < 1\}$ defined by $f(x) = \frac{x}{1+|x|}$,
 $x \in \mathbb{R}$ is a one-one onto function

- 33 The equilibrium conditions for three competitive markets are described as given below, where m_1, m_2 and m_3 are the equilibrium price for each market respectively.

$$m_1 + 2m_2 + 3m_3 = 85$$

$$3m_1 + 2m_2 + 2m_3 = 105$$

$$2m_1 + 3m_2 + 2m_3 = 110$$

Using matrix method, find the values of respective equilibrium prices

- 34 Find $\frac{dy}{dx}$ of the function $x^y + x^x + y^x = a^b$

- OR -

If $y = Ae^{mx} + Be^{nx}$, show that $\frac{d^2y}{dx^2} - (m+n)\frac{dy}{dx} + mny = 0$

- 35 Integrate the function $\int \frac{1}{\cos(x+a)\cos(x+b)} dx$

SECTION – E

(CASE STUDY - Each Question Carries 4 Marks)

- 36 Read the following passage and answer the questions given below.

The temperature of a person during an intestinal illness is given by $f(x) = -0.1x^2 + mx + 98.6$, $0 \leq x \leq 12$, m being a constant, where $f(x)$ is the temperature in F^0 at x days.



- (i) Is the function differentiable in the interval $(0, 12)$? Justify your answer (1m)
(ii) If 6 is the critical point of the function, then find the value of the constant m (1m)
(iii) Find the intervals in which the function is strictly increasing / strictly decreasing. (2m)

- OR -

Find the points of local maximum / local minimum, if any, in the interval $(0, 12)$ as well as the points of absolute maximum / absolute minimum in the interval $[0, 12]$. Also, find the corresponding local maximum / local minimum. (2m)

37 For an EMC project, a student of Class XII makes an open cardboard box for a jewelry shop from a square sheet of side 12 cm by cutting off squares from each corner and folding up the flaps. Assume that 'x' be the side of squares cut off from each corner. Based on the given information, answer the following questions.

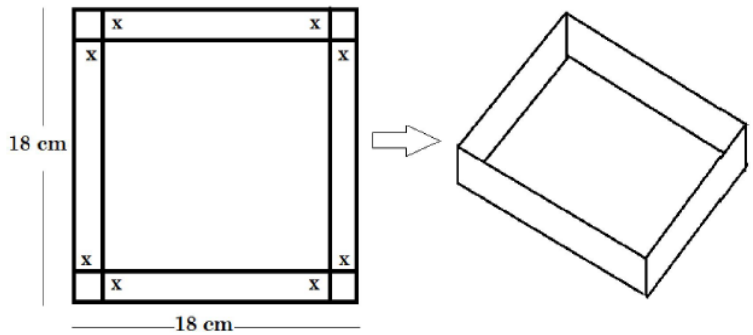

- (i) For the open box, find the length, breadth and height in terms of x . (1m)
- (ii) Write an expression for the volume of the open box. (1m)
- (iii) For what value of 'x', the open box will have maximum volume? (2m)

- OR -

Find the maximum value of volume of the open box. (2m)

38 Gautam buys 5 pens, 3 bags and 1 instrument box and pays a sum of ₹160. From the same shop, Vikram buys 2 pens, 1 bag and 3 instrument boxes and pays a sum of ₹190. Also, Ankur buys 1 pen, 2 bags and 4 instrument boxes and pays a sum of ₹250. Based on the above information, answer the following questions.



- (i) Convert the given above situation into a matrix equation of the form $AX = B$ (1m)
- (ii) Find $|A|$ (1m)
- (iii) Find A^{-1} (2m)

- OR -

Determine $P = A^2 - 5A$ (2m)